



Insight — Application Note 3.27

Parallel Plate Measurements

Electrical model of thermosets

Dielectric instrumentation measures the electrical properties of the Material Under Test (MUT) between a pair of electrodes, which can be modeled as a conductance in parallel with a capacitance, as shown in Figure 27-1.

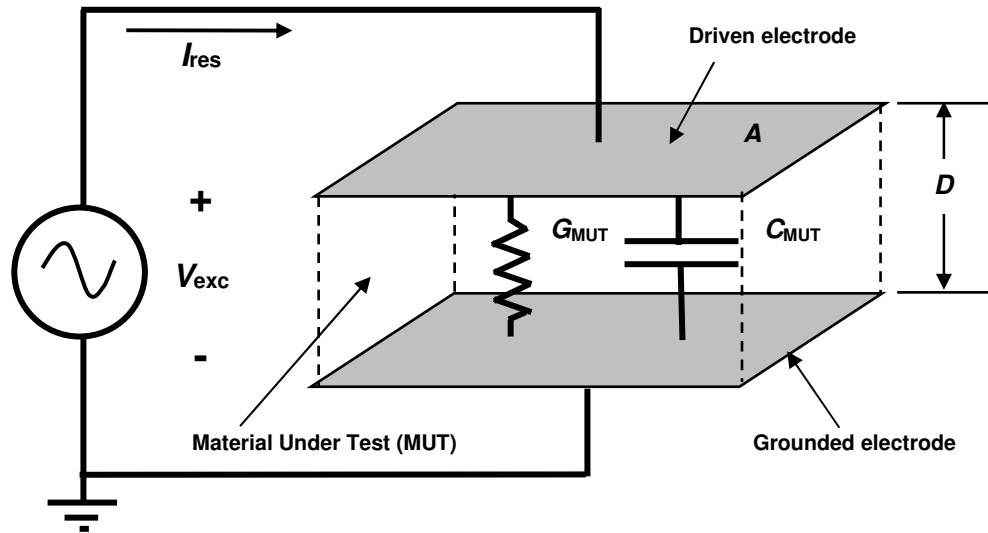

Figure 27-1
Electrical model of dielectric Material Under Test

Raw dielectric measurements at frequency f are conductance G_{MUT} (ohm^{-1}) and capacitance C_{MUT} (farads). Resistance and other material properties are given by equations 27-1 through 27-5:

(eq. 27-1)	$R_{MUT} = 1/G_{MUT}$	(resistance)
(eq. 27-2)	$\rho = R_{MUT} A/D$	(resistivity or ion viscosity)
(eq. 27-3)	$\sigma = G_{MUT} / (A/D)$	(conductivity)
(eq. 27-4)	$\epsilon' = C_{MUT} / (\epsilon_0 A/D)$	(relative permittivity)
(eq. 27-5)	$\epsilon'' = \sigma / (\epsilon_0 \omega)$	(loss factor)

Where:

$$\omega = 2\pi f$$

$$\epsilon_0 = 8.85 \times 10^{-14} \text{ F/cm}$$

A/D = ratio of area to distance for electrodes

Dissipation, or $\tan \delta$, at measurement frequency f is the ratio of a material's relative loss to its relative permittivity, and is given by the relationship:

(eq. 27-6)
$$\tan \delta = \epsilon'' / \epsilon' = 1 / (\omega C_{MUT} R_{MUT})$$

Dielectric properties can be measured in a test cell, and parallel plate electrodes are usually used for solid material in the form of a laminate or panel. Some test cells have cylindrical geometries for measuring fluids or tubular solids, and many other configurations are possible. In general the A/D ratio may also be called the *cell constant*.

ASTM standard for parallel plate dielectric measurements

The ASTM standard D150-98 (Reapproved 2004) **Standard Test Methods for DAC Loss Characteristics and Permittivity (Dielectric Constant) of Solid Electrical Insulation** describes general configurations of electrodes, circuits and instruments. For measurements that do not require best accuracy, unshielded two-electrode systems with corrections may be convenient, but exacting measurements require guarded three-electrode fixtures.

An unshielded two-electrode arrangement produces fringing electric fields between the electrodes and through the sample and surrounding media, as shown in Figure 27-2. These fringe fields create stray capacitance that introduces uncertainty in the A/D ratio, or cell constant, and reduces measurement accuracy.

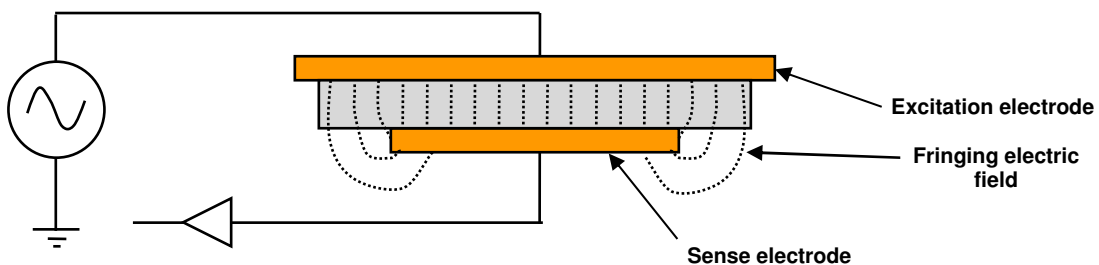

Figure 27-2
Unguarded parallel plate electrodes with fringing electric field

Guarded three-electrode fixtures are the standard for accurate dielectric measurements. In this configuration, a guard electrode surrounds the response electrode. Additional circuitry drives the guard electrode with a reproduction of the response voltage. Most impedance measurement instruments, such as LCR

meters, connect the response electrode to a virtual ground; in this case the guard electrode is also grounded.

Figure 27-3 shows how the guard electrode creates a uniform electric field that extends beyond the sample. This configuration eliminates fringing fields and allows exact definition of the A/D ratio or cell constant, based on the dimensions of the electrodes alone. Also, because the electric field between excitation and response electrodes is confined to the sample, the medium beyond the sample does not influence the measurement.

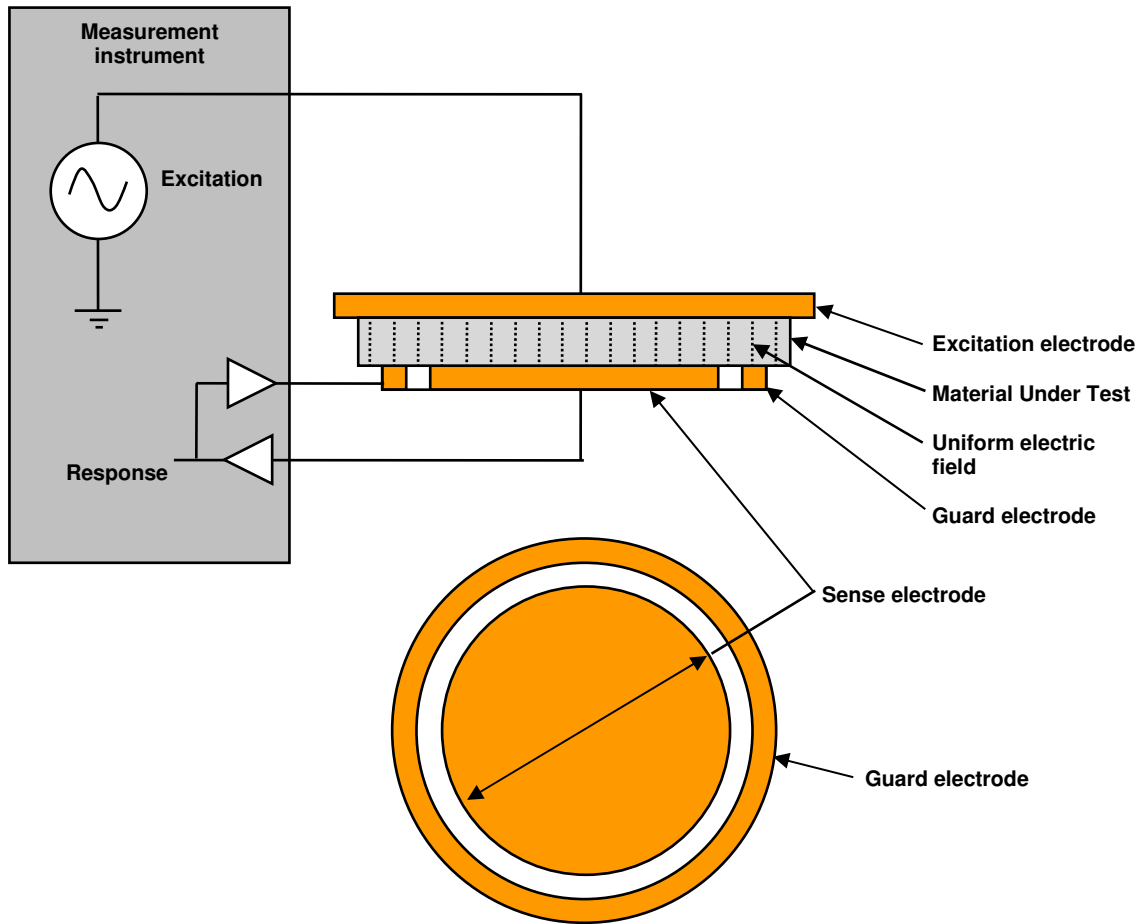

Figure 27-3
Guarded parallel plate electrodes with uniform electric field

Cabling to instruments

For accurate measurements, good cabling is important. Figure 27-4 shows the typical connection of an instrument to a parallel plate test fixture. The excitation line uses a coaxial cable and the response line uses a triaxial cable. The shield of the coaxial cable is grounded to prevent coupling of the excitation to the response signal. The inner shield of the triaxial cable is driven by a buffered version of the response signal; this method of signal *guarding* reduces the effect of input and cable capacitance for small voltages at high impedance levels. The guard output also drives the guard electrode of the test fixture. The outer shield of the triaxial cable is grounded to prevent transmission of noise to the guard signal. When the response line is a virtual ground, which is the case for most LCR meters, a coaxial cable with grounded shield is sufficient for the response signal.

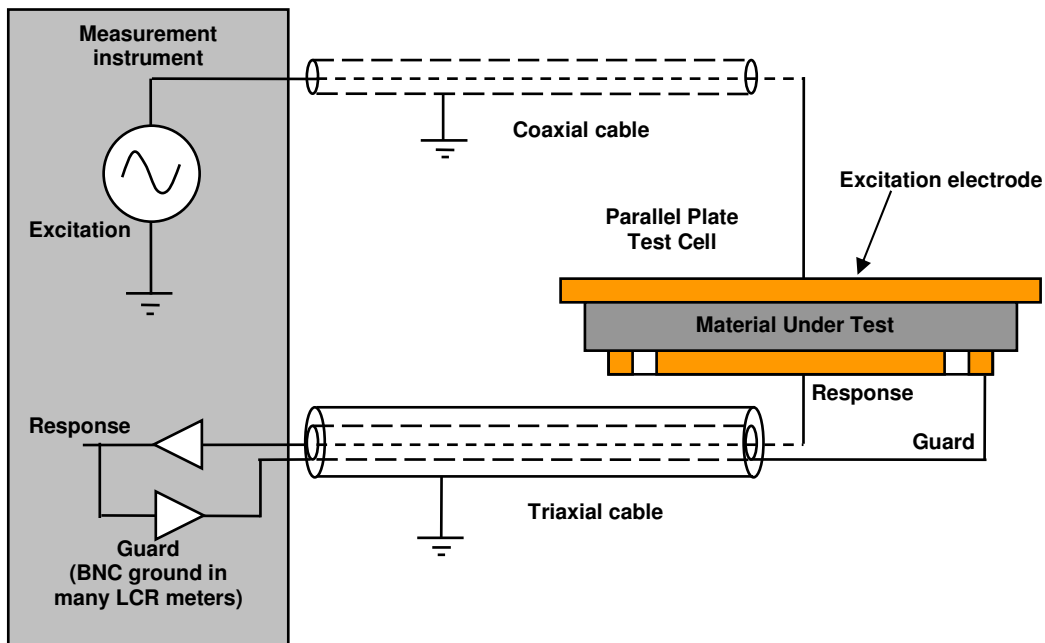

Figure 27-4

Typical excitation and response cabling to a parallel plate test fixture

Contacting electrode measurements

The contacting electrode method requires only one measurement with the electrodes in direct contact with the MUT as shown in Figure 27-5. The surface of the MUT must be flat to prevent an air gap between the sample and electrodes. The MUT should also be incompressible so the separation between the electrodes is the same as the true thickness of the sample.

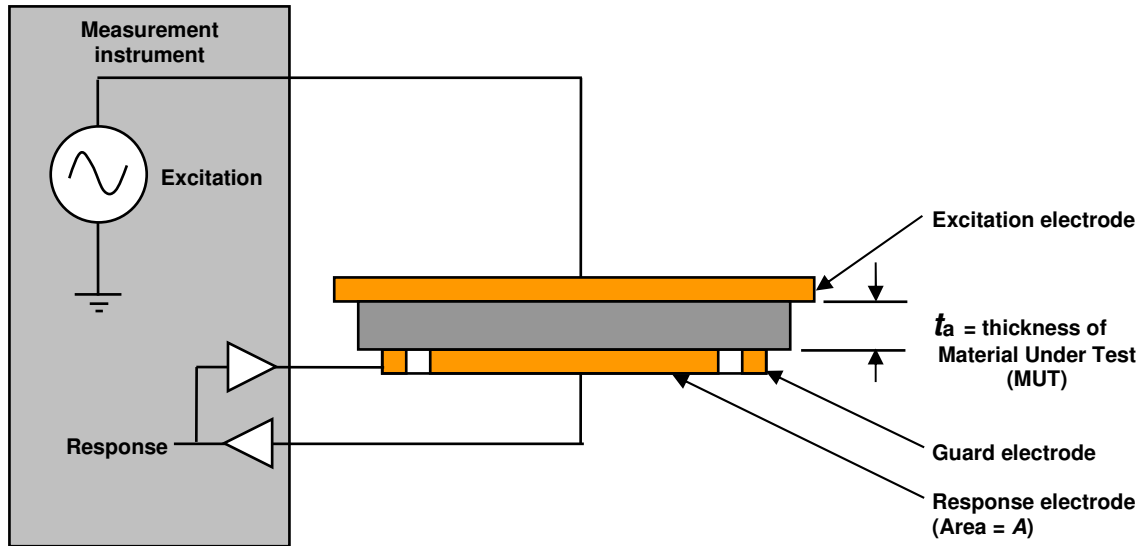

Figure 27-5
Configuration for contacting electrode measurements

Dielectric properties at f , the frequency of measurement, are calculated below:

$$\begin{aligned} \text{(eq. 27-7)} \quad \epsilon' &= C_P / (\epsilon_0 A / t_a) \\ \text{(eq. 27-8)} \quad \tan \delta &= \epsilon'' / \epsilon' = 1 / (\omega C_P R_P) \\ \text{(eq. 27-9)} \quad \epsilon'' &= \epsilon' \tan \delta \end{aligned}$$

Where: $\omega = 2\pi f$
 $\epsilon_0 = 8.85 \times 10^{-14} \text{ F/cm}$
 $C_P = \text{Capacitance of measurement (farad)}$
 $R_P = \text{Resistance of measurement (ohm)}$

Non-contacting electrode measurements

The non-contacting electrode method can obtain accurate results for dielectric properties in the presence of an air gap, but requires two measurements. The first measurement determines the capacitance and dissipation of the test fixture at a known separation with only air between the electrodes, as shown in Figure 27-6a. The second measurement determines the capacitance and dissipation at the same separation with the sample inserted between the electrodes, as shown in Figure 27-6b. For this method the air gap and the compressibility of the MUT do not affect the results.

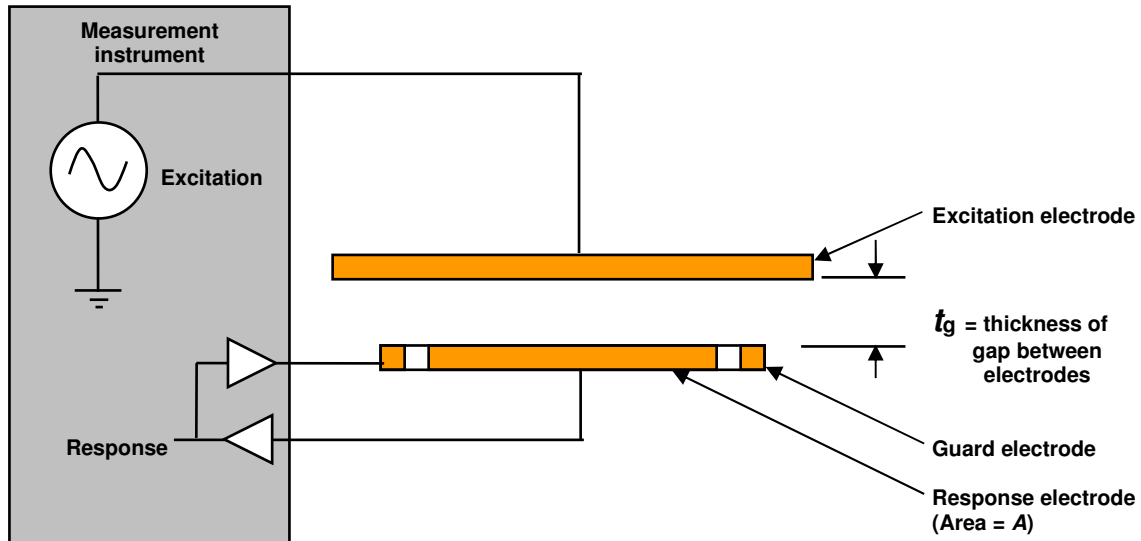

Figure 27-6a
Non-contacting electrode measurement with air only between electrodes
(First measurement)

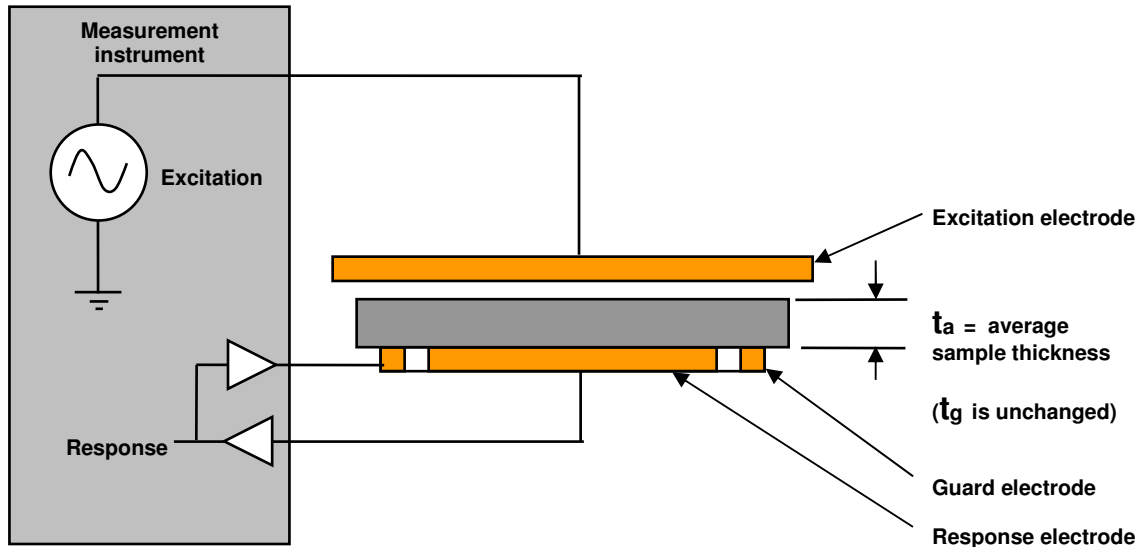

Figure 27-6b
Non-contacting electrode measurement with sample between electrodes
(Second measurement)

For low dissipation the dielectric properties at f , the frequency of measurement, are calculated below:

For $(\tan \delta)^2 \ll 1$

(eq. 27-10) $\epsilon' = 1 / [1 - (a b)]$

(eq. 27-11) $\tan \delta = \tan \delta_{P2} + [\epsilon' c d]$

(eq. 27-12) $\epsilon'' = \epsilon' \tan \delta$

Where: $\omega = 2\pi f$

C_{P1} = Capacitance (F) without MUT inserted (Fig. 27-6a)

R_{P1} = Resistance (Ω) without MUT inserted (Fig. 27-6a)

$\tan \delta_{P1} = 1 / (\omega C_{P1} R_{P1})$ = Dissipation without MUT inserted
(Fig. 27-6a)

C_{P2} = Capacitance (F) with MUT inserted (Fig. 27-6b)

R_{P2} = Resistance (Ω) with MUT inserted (Fig. 27-6b)

$\tan \delta_{P2} = 1 / (\omega C_{P2} R_{P2})$ = Dissipation with MUT inserted
(Fig. 27-6b)

t_g = Separation (m) between electrodes

t_a = Average sample thickness (m)

$a = 1 - (C_{P1} / C_{P2})$

$b = t_g / t_a$

$c = \tan \delta_{P2} - \tan \delta_{P1}$

$d = (t_g / t_a) - 1$

Results for non-contacting electrode measurements can only be as accurate as the measurements of electrode separation and sample thickness. For situations where the air gap is a large fraction of the sample thickness, calculations for relative permittivity, ϵ' , and dissipation, $\tan \delta$, are very sensitive to uncertainties in t_g and t_a . Consequently, non-contacting electrode measurements are best used for thicker samples where the air gap can be relatively small.



Lambient Technologies, LLC
649 Massachusetts Ave., Cambridge MA 02139, USA
(857) 242-3963
<https://lambient.com>
info@lambient.com