

AN 10—Interfacing to Terminal Blocks

Introduction

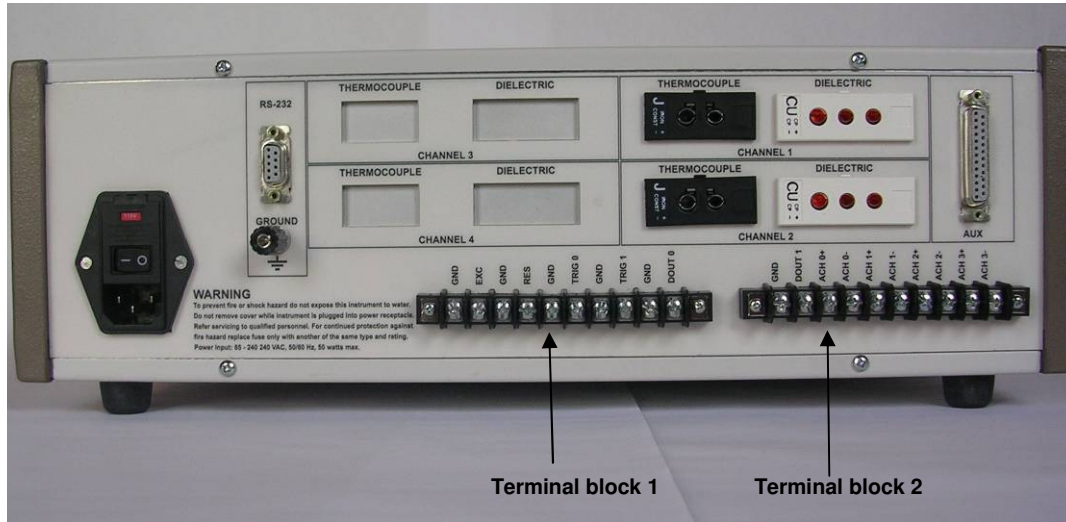

Figure AN-1
LT-451 rear panel (LTF-631 is similar)

The LT-451/LTF-631 has two terminal blocks on the rear panel as shown in Figure AN-1. The contacts have functions as listed below:

- **Terminal block 1**—Connection to instrument functions as noted below:
 - GND—System ground connection.
 - EXC—Excitation signal output for diagnostics.
 - GND—System ground connection.
 - RES—Response signal output for diagnostics.
 - TRIG0—Trigger 0 input. Can be used to initiate automatic start of data acquisition. Initiates operation in “Safe Mode” if connected to GND during instrument start-up.
 - GND—System ground connection.
 - TRIG1—Trigger 1 input. Can be used to initiate automatic start of data acquisition.
 - GND—System ground connection.
 - DOUT0—Digital 0 output. Outputs TTL level signal (“0” = 0 V, “1” = 5 V) under control of CureView software.

- **Terminal block 2**—Connection to instrument functions as noted below:
 - GND—System ground connection.
 - DOUT1-- Digital 1 output. Outputs TTL level signal (“0” = 0 V, “1” = 5 V) under control of CureView software.
 - ACH 0+ --Analog input channel 0 high side.
 - Differential input for the LT-451. Input range is ± 10.0 V differential.
 - Single ended input for the LTF-631. Input range is 0.0-4.0 V. This input is disabled if the Kistler Amplifier Option is installed.
 - ACH 0- --Analog input channel 0 low side.
 - Differential input for the LT-451. Input range is ± 10.0 V differential.
 - Input is 0.0 V for the LTF-631. This input is disabled if the Kistler Amplifier Option is installed.
 - ACH 1+ --Analog input channel 0 high side.
 - Differential input for the LT-451. Input range is ± 10.0 V differential.
 - Single ended input for the LTF-631. Input range is 0.0-4.0 V. This input is disabled if the Kistler Amplifier Option is installed.
 - ACH 1- --Analog input channel 0 low side.
 - Differential input for the LT-451. Input range is ± 10.0 V differential.
 - Input is 0.0 V for the LTF-631. This input is disabled if the Kistler Amplifier Option is installed.
 - ACH 2+ --Analog input channel 0, high side differential input for the LT-451 only. Input range is ± 10.0 V differential. No function for LTF-631.
 - ACH 2- --Analog input channel 0, low side differential input for the LT-451 only. Input range is ± 10.0 V differential. No function for LTF-631.
 - ACH 3+ --Analog input channel 0, high side differential input. Input range is ± 10.0 V differential. No function for LTF-631.
 - ACH 3- --Analog input channel 0, low side differential input. Input range is ± 10.0 V differential. No function for LTF-631.

Interfacing to Start Triggers

The LT-451/LTF-631 has two inputs for triggers which start data acquisition. They are identified as TRIG0 and TRIG1 on Terminal Block 1, and are designed to be triggered by an isolated contact closure to ground (GND) as shown in Figure AN-2.

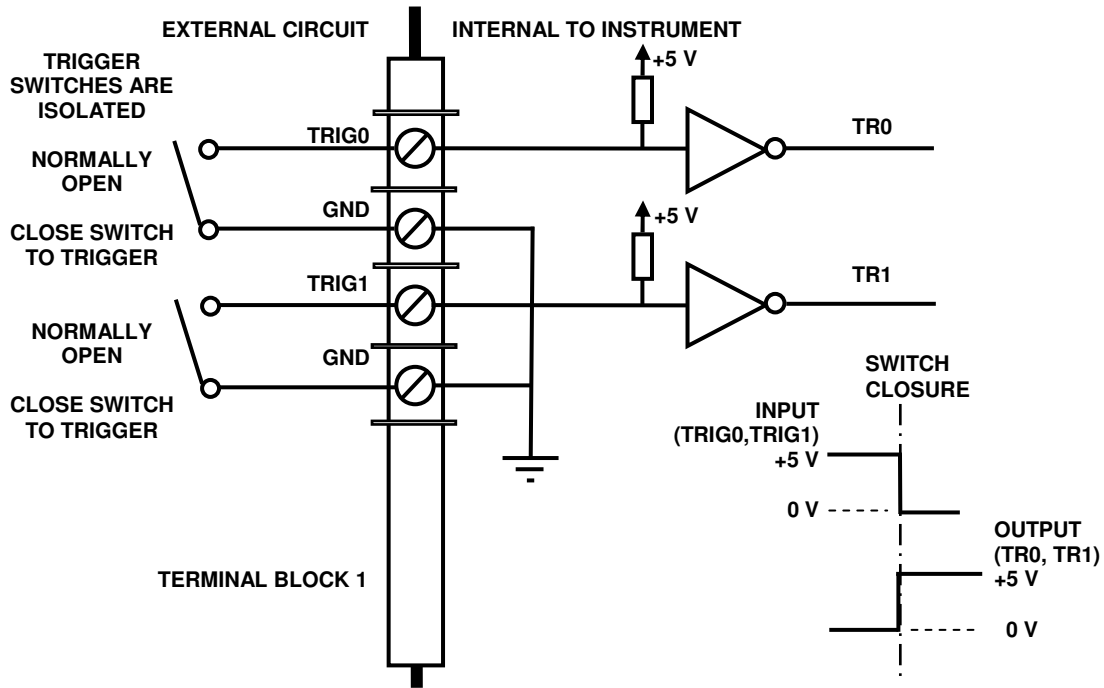

Figure AN-2
Recommended method of implementing start triggers

The user only has to connect isolated switches or relay contacts between TRIG0 and GND to use TRIG0 to start data acquisition. The contacts should be NORMALLY OPEN, and should close at the desired time of triggering. The configuration is the same for using TRIG1 to start data acquisition.

The voltages measured on TRIG0 and TRIG1 behave as shown on Table AN-1:

Table AN-1
Behavior of TRIG0 and TRIG1

STATE	TERMINAL VOLTAGE		ACTION
	TRIG0	TRIG1	
Switch contact open	+5 VDC	+5 VDC	No action
Switch contact closed	0 VDC	0 VDC	Start data acquisition

At the beginning of a run, the CureView software displays the following **Start Test Run** window:

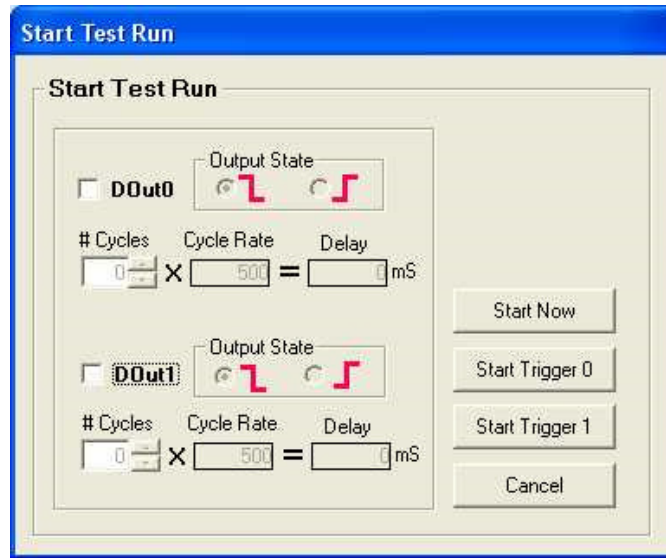

Figure AN-3
Start trigger set-up window

The user may select from the following options to start data acquisition:

- **Start Now**—Immediate, manual start.
- **Start Trigger 0**—Wait for contact closure on TRIG0 before start.

Clicking **Start Trigger 0** changes the desired starting trigger to TRIG0, as shown in Figure AN-4:

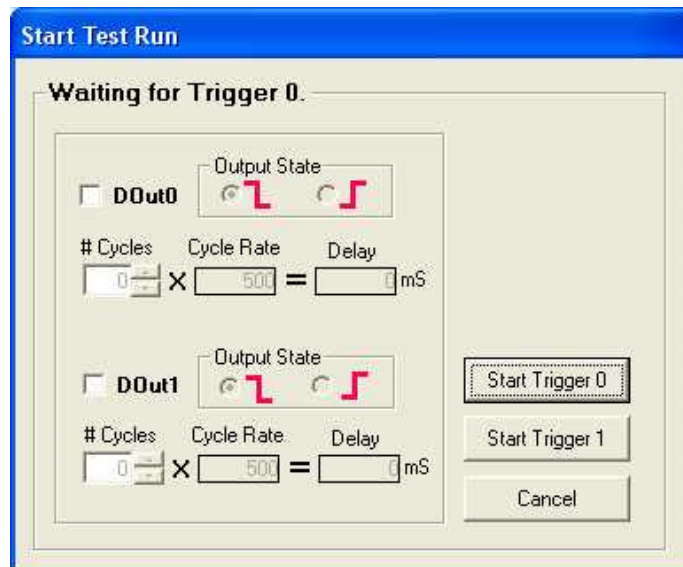

Figure AN-4
Start trigger set-up window—Start on TRIG0

- **Start Trigger 1**—Wait for contact closure on TRIG1 before start.

Clicking **Start Trigger 1** changes the desired starting trigger to TRIG1, as shown in Figure AN-5:

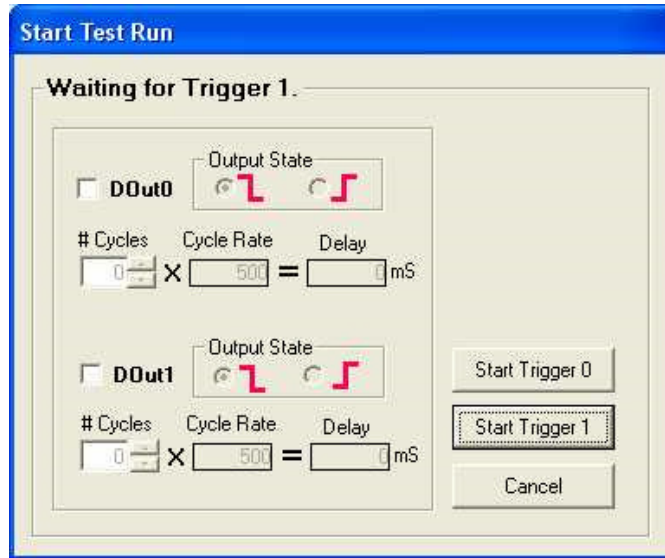

Figure AN-5
Start trigger set-up window—Start on TRIG1

Testing the Start Trigger

If **Start Trigger 0** or **Start Trigger 1** is selected, then the instrument will wait for the appropriate contact closure before starting data acquisition. This function may be tested by setting up CureView for a run, and then shorting the selected trigger—either TRIG0 or TRIG1—to ground (GND). A successful trigger will begin a run, and the plot on CureView will begin to display data.

Interfacing to Digital Outputs

The LT-451/LTF-631 has two digital outputs which can be used to control switches or other devices. They are identified as DOUT0 (located on Terminal Block 1) and DOUT1 (located on Terminal Block 2). Their output characteristics are listed in Table AN-2.

Table AN-2
Output characteristics of DOUT0 and DOUT1

STATE	OUTPUT VOLTAGE		ACTION
	DOUT0	DOUT1	
“Low” or “0”	0 VDC	0 VDC	Current sink (4 mA max)
“High” or “1”	+5 VDC	+5 VDC	Current source (4 mA max)

DOUT0 and DOUT1 are **not** designed to directly drive relays or switches, but require amplifiers, buffer circuits or solid state relays with low input currents as shown in Figure AN-6. If used, the amplifiers, buffer circuits or solid state relays must have input currents less than 4 mA and must not cause the terminal voltage of DOUT0 or DOUT1 to exceed +5 VDC.

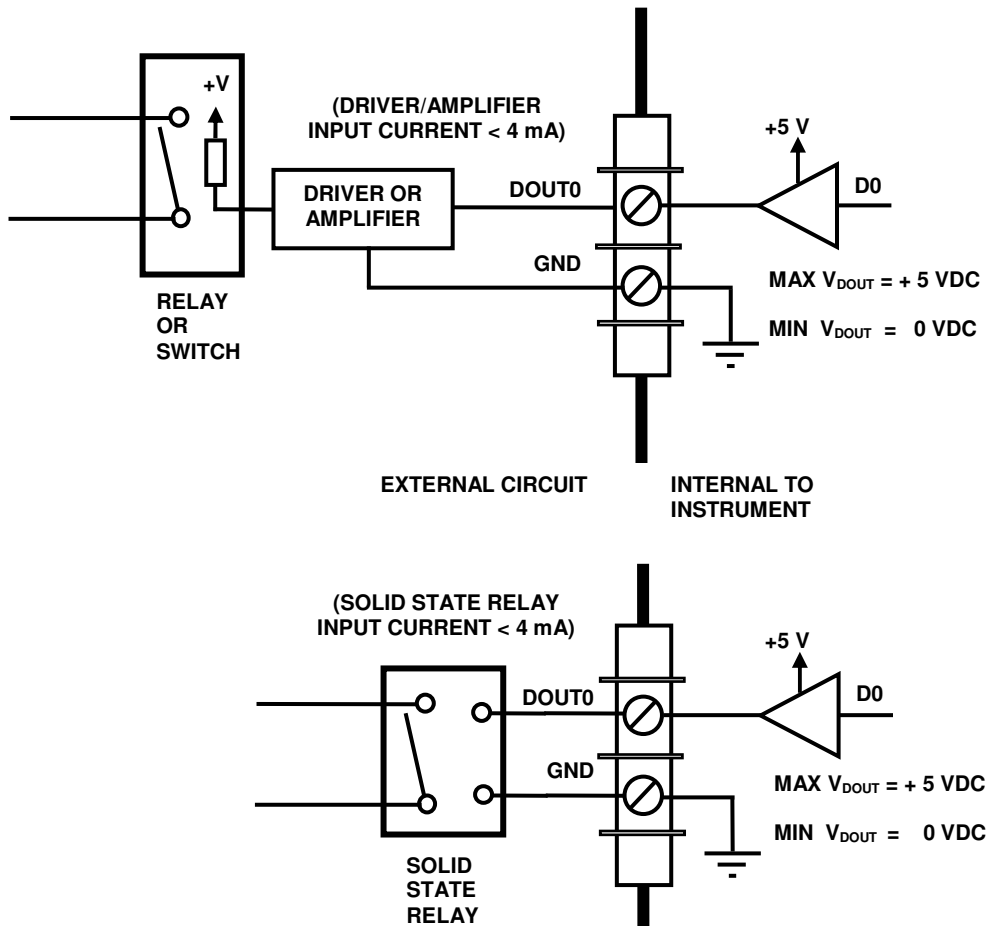

Figure AN-6

Recommended methods for interfacing to digital outputs

Figure AN-7 shows an incorrect way to interface with the digital outputs. The coil of the relay is directly connected to DOUT0 and requires more than 4 mA to energize the coil and close the contacts. Furthermore, if the voltage +V of the relay coil is greater than +5 VDC, this connection will damage the internal circuit of the instrument.

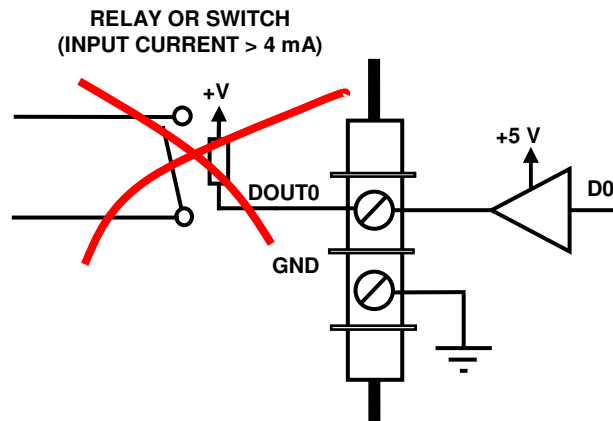

Figure AN-7
Incorrect interfacing to digital outputs

Testing the Digital Outputs

Before the start of data acquisition, CureView displays the **Start Test Run** window of Figure AN-8. The user can enable the digital outputs by checking **DOut0** and/or **DOut1**.

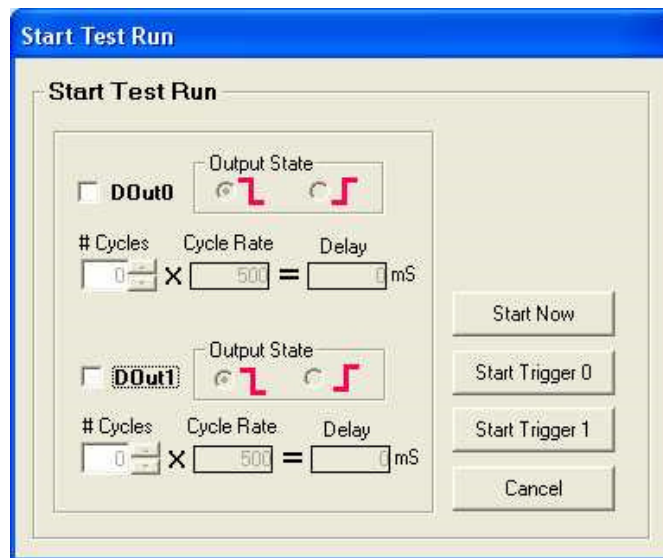

Figure AN-8

Clicking on the left **Output State** option (“High” to “Low”) immediately sets the selected digital output “high” (+5 V) in preparation for data acquisition. After the run has started, and after the selected number of measurement cycles, the digital output will go “low” (0 V).

Conversely, clicking on the right **Output State** option (“Low” to “High”) immediately sets the selected digital output “low” (0 V) in preparation for data acquisition. After the run has started, and after the selected number of measurement cycles, the digital output will go “high” (+5 V).

The digital outputs can be tested by measuring the voltage at DOUT0 and DOUT1 while clicking on the left (“High” to “Low”) and right (“Low” to “High”) **Output State** options. The digital outputs should change immediately as shown in Table AN-3:

Table AN-3
Output DOUT0 and DOUT1 before start of run

Output State Setting	OUTPUT VOLTAGE	
	DOUT0 Enabled	DOUT1 Enabled
Right (“High” to “Low”)	+5 VDC	+5 VDC
Left (“Low” to “High”)	0 VDC	0 VDC