



***Insight* — Application Note 3.29**

Electrode Polarization and Boundary Layer Effects

Causes of electrode polarization

When the incorrect model is used to determine dielectric properties, low frequency measurements of highly conductive materials may appear to have unusually low conductivity. This phenomenon is caused by electrode polarization, the accumulation of charge against the electrodes, which occurs when the material under test:

- Has high loss factor (high ionic conduction at low frequency)
- AND
- Has a non-conductive film, an oxide layer or an electrochemical potential barrier, resulting in an insulating boundary layer

If the effects of electrode polarization and boundary layers are properly considered, then it is possible to account for their influence and correctly calculate bulk permittivity and conductivity.

Effects of electrode polarization

Electrode polarization distorts dielectric data by artificially increasing *apparent* relative permittivity (ϵ') and decreasing *apparent* loss factor (ϵ''). When plotted against time, loss factor curves may display anomalous behavior as shown in Figure 29-1.

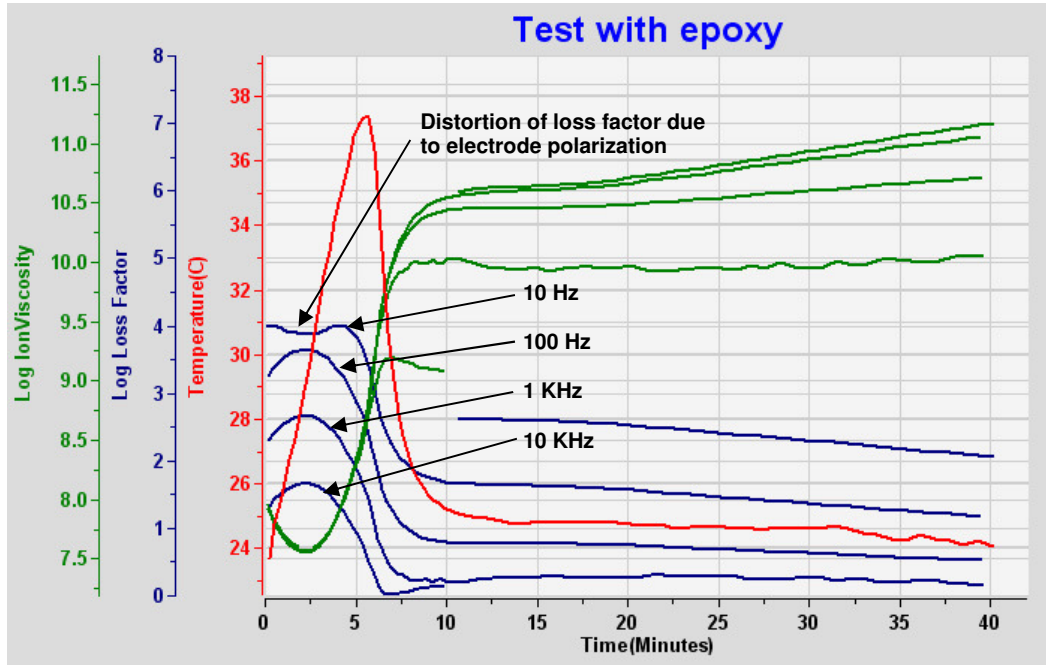

Figure 29-1
Plot showing distortion of loss factor due to electrode polarization

This distortion increases as loss factor increases. In addition, lower frequencies correspond to higher loss factors for a given conductivity, and therefore display even greater distortion. As a result, the 10 Hz loss factor data of Figure 29-1 shows a double hump—a depression with two satellite peaks instead of a single peak. The first satellite peak has been attributed to softening, and the second satellite peak to gelation—but they both are artifacts from use of an incorrect model and do not describe actual dielectric events. In fact, the expected—but unseen—single loss factor peak corresponds to the point of minimum viscosity, an event that would be completely lost if the data were misinterpreted.

The loss factor data of Figure 29-1 can be plotted against permittivity to highlight the nature of these relationships, as shown in Figure 29-2.

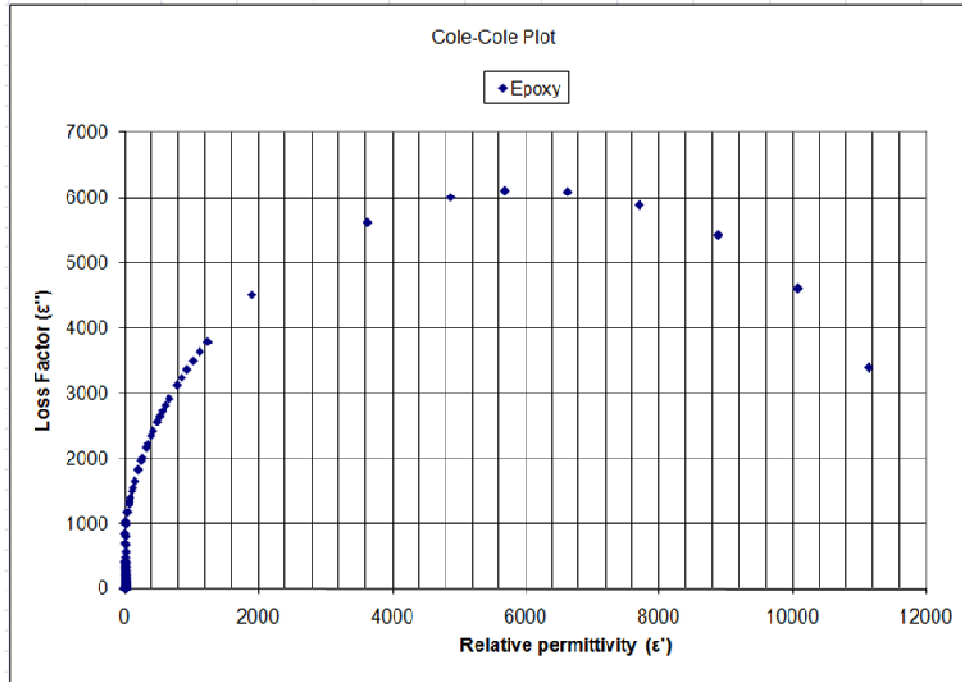

Figure 29-2
Cole-Cole plot of epoxy cure data distorted by electrode polarization

In older literature this Cole-Cole plot behavior has been erroneously explained by a large dipole relaxation response.

Basic circuit model of a dielectric material

The basic model of a dielectric Material Under Test consists of a conductance G_{MUT} in parallel with a capacitance C_{MUT} as shown below in Figure 29-3. This configuration has a simple relationship between the excitation voltage V_{exc} across the material and the response current I_{res} through the material, given by equation 29-1:

$$(eq. 29-1) \quad I_{res} / V_{exc} = G_{MUT} + i\omega C_{MUT} = Y_{MUT}$$

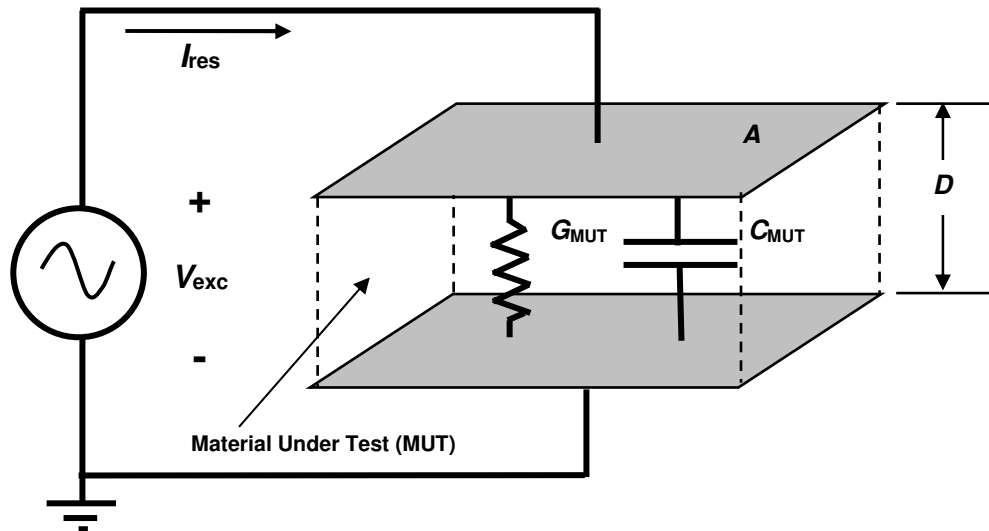

Figure 29-3
Basic model of a dielectric material

Boundary layers

Electrode polarization creates a boundary layer at the interface with the material and changes the model to that of Figure 29-4:

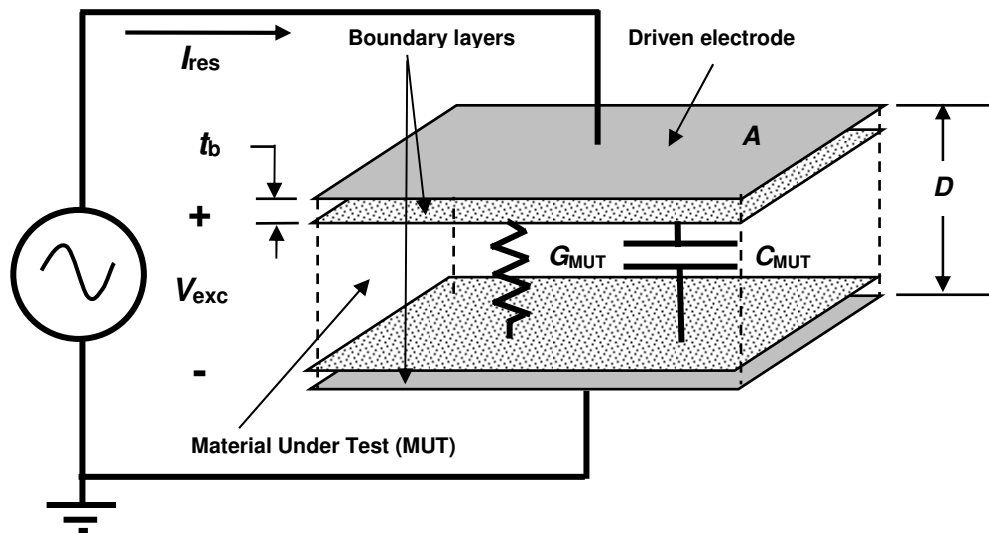

Figure 29-4
Model of dielectric material with boundary layer

Boundary layers are very thin (thickness = t_b) and have the surface area of the electrodes. Consequently they have a very large A/D ratio, resulting in a large

capacitance C_B in series with the bulk material. This arrangement is shown in the circuit model of Figure 29-5.

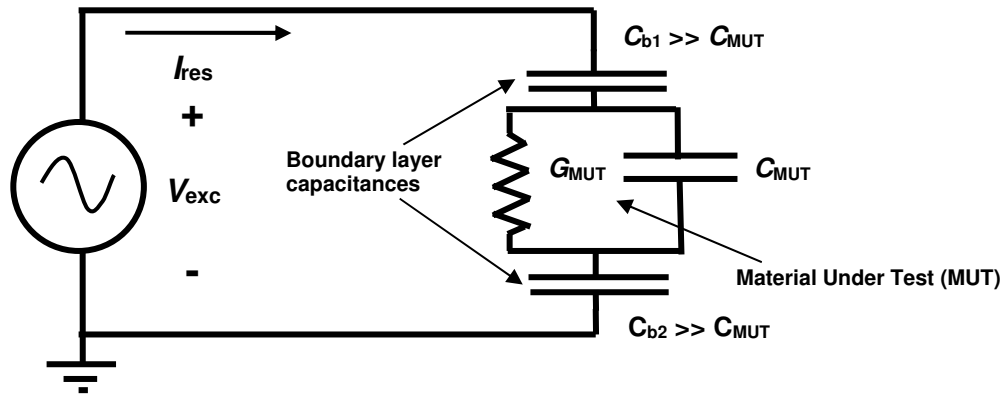

Figure 29-5
Circuit model of dielectric with boundary layer capacitances

Analysis of the boundary layer model is much more complicated than for the basic model, but it is possible to quickly understand the circuit behavior in certain limiting cases.

Low frequency response of boundary layers

For situations with low excitation frequency or high bulk conductivity, the boundary layer capacitances dominate the circuit response and the model of Figure 29-5 reduces to Figure 29-6. Capacitances act as open circuits at low frequencies, so the boundary layer blocks DC current. Measurements of DC conductance are impossible in this case and the material appears primarily insulating or capacitive.

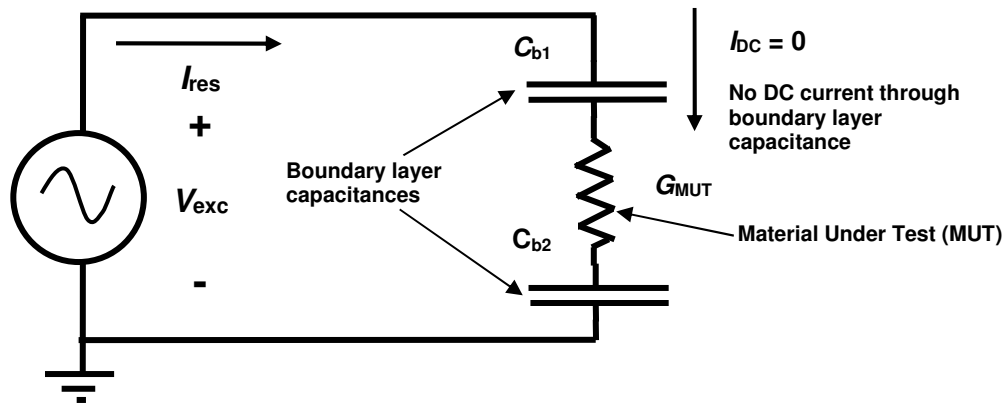

Figure 29-6
Low frequency circuit model with boundary layer capacitances

High frequency response of boundary layers

For the limit of high frequency or low bulk conductivity, boundary layer admittance is high compared to the Material Under Test, and boundary layer capacitances act like short circuits. In this case the circuit of Figure 29-5 reduces to the simpler one of Figure 29-7, which is identical to the basic model of a dielectric material. Therefore, at sufficiently high frequency, the behavior of a dielectric material is the same with or without boundary layers.

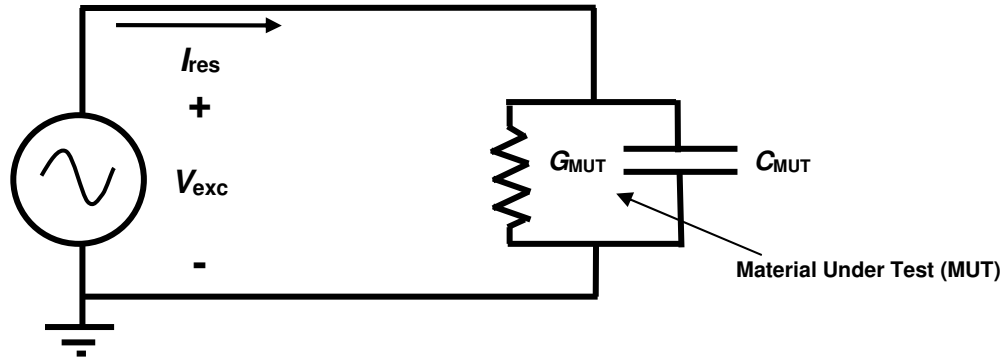

Figure 29-7
High frequency circuit model with boundary layer capacitances
(Also applies to low bulk conductivity)

Boundary layer effect on dielectric cure monitoring

It is possible to calculate the following dielectric material properties from measurements of a material's conductance and capacitance:

(eq. 29-2)	$\sigma = G_{MUT} / (A/D)$	(conductivity)
(eq. 29-3)	$\epsilon' = C_{MUT} / (\epsilon_0 A/D)$	(relative permittivity)
(eq. 29-4)	$\epsilon'' = \sigma / (\epsilon_0 \omega)$	(loss factor)
(eq. 29-5)	$\rho = (A/D) / G_{MUT}$	(resistivity)

Where:

$$\omega = 2\pi f_{exc}$$

$$\epsilon_0 = 8.85 \times 10^{-14} \text{ F/cm}$$

A/D = ratio of area to distance for electrodes

A common convention describes the cure of a polymeric material in terms of relative permittivity, ϵ' , and loss factor, ϵ'' . The boundary layer model of Figure 29-6 can be solved using these terms as follows:¹

$$\text{(eq. 29-6)} \quad \epsilon'_x = \epsilon' (D / 2t_b) \frac{(\epsilon''/\epsilon')^2 + (D / 2t_b)}{(\epsilon''/\epsilon')^2 + (D / 2t_b)^2}$$

$$\text{(eq. 29-7)} \quad \epsilon''_x = \epsilon'' (D / 2t_b) \frac{(D / 2t_b) - 1}{(\epsilon''/\epsilon')^2 + (D / 2t_b)^2}$$

$$\text{(eq. 29-8)} \quad \tan \delta_x = \epsilon''_x / \epsilon'_x = \tan \delta [((D / 2t_b) - 1) / ((\tan \delta)^2 + (D / 2t_b))]$$

Where:

- t_b = boundary layer thickness
- D = distance between electrodes or plate separation
- ϵ'_x = uncorrected (apparent) permittivity
- ϵ''_x = uncorrected (apparent) loss factor
- ϵ' = actual permittivity
- ϵ'' = actual loss factor
- $\tan \delta = \epsilon''/\epsilon'$

Figure 29-8 shows how boundary layer thickness, temperature, frequency and state of cure influence the Cole-Cole plot of a curing material. With no boundary layer, loss factor decreases with advancing cure, while permittivity remains constant at the value ϵ_r , called the relaxed permittivity. Thicker boundary layers cause the Cole-Cole plot to develop a curvature which in extreme cases can become a complete semi-circle.

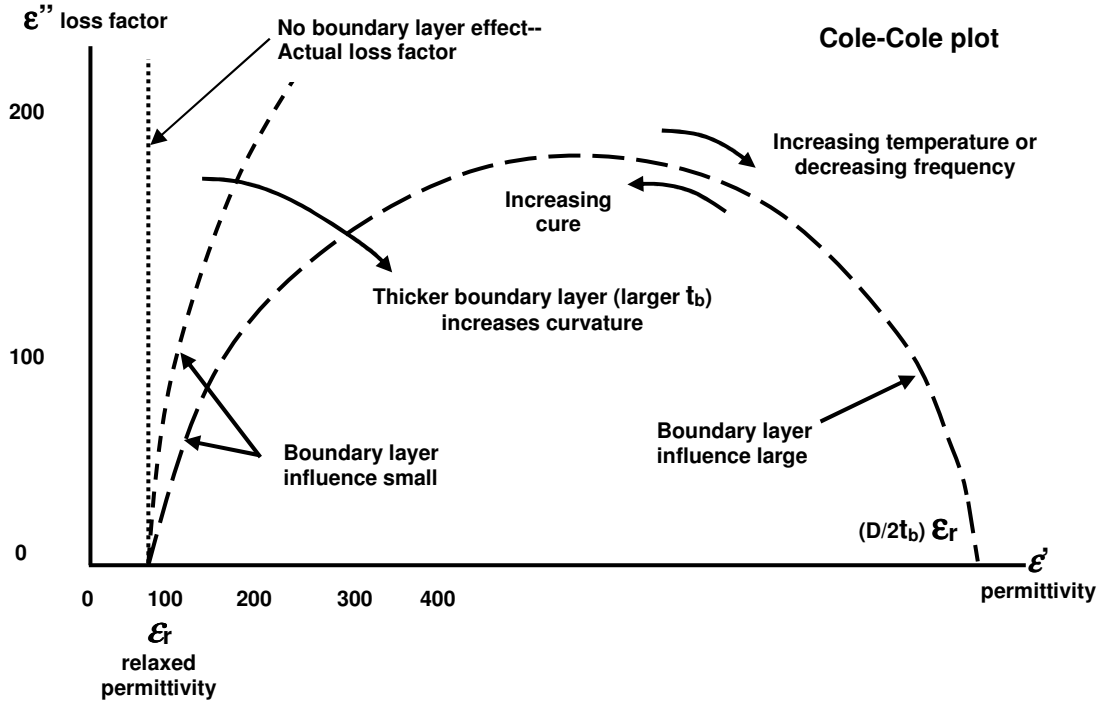

Figure 29-8
Cole-Cole plot of curing material with boundary layer effect

The left intercept of the semi-circle is the relaxed permittivity ϵ_r , and the right intercept is determined by both ϵ_r and the ratio $D/2t_b$. This information can be used to calculate the boundary layer thickness t_b . In the absence of an artificial blocking layer such as an applied insulator or an oxide coating, the boundary layer thickness can be used to calculate an approximate mobile ion concentration $[C]$ and ion mobility μ :²

$$(eq. 29-9) \quad [C] = (t_b^2 q^2) / (2kT\epsilon'\epsilon_0)$$

$$(eq. 29-10) \quad \mu = \sigma / ([C] q)$$

Where :
 k = Boltzmann's constant (eV/K)
 T = temperature in degrees Kelvin (K)
 q = magnitude of electronic charge (coulombs)
 μ = free ion mobility (cm² / (V-s))

Electrode polarization correction

It is possible to manipulate equations 29-6, 29-7 and 29-8 to correct the effect of electrode polarization in certain cases. Figure 29-9 shows data that has been adjusted in this manner.

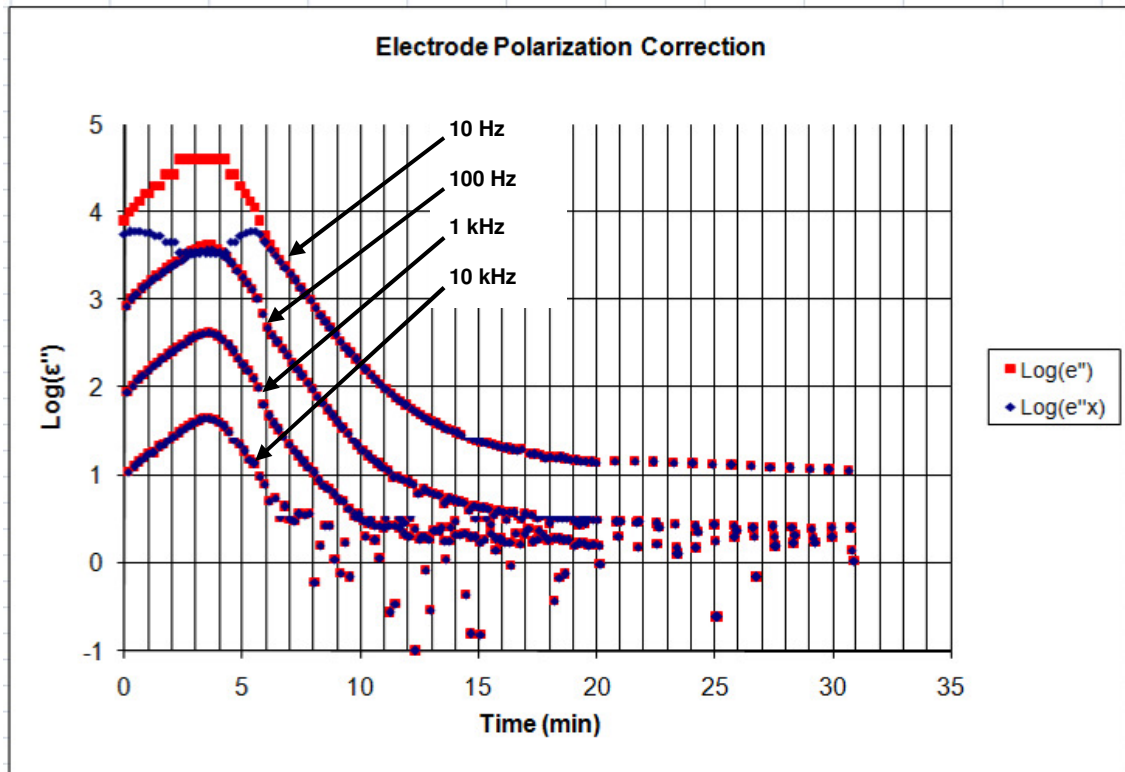
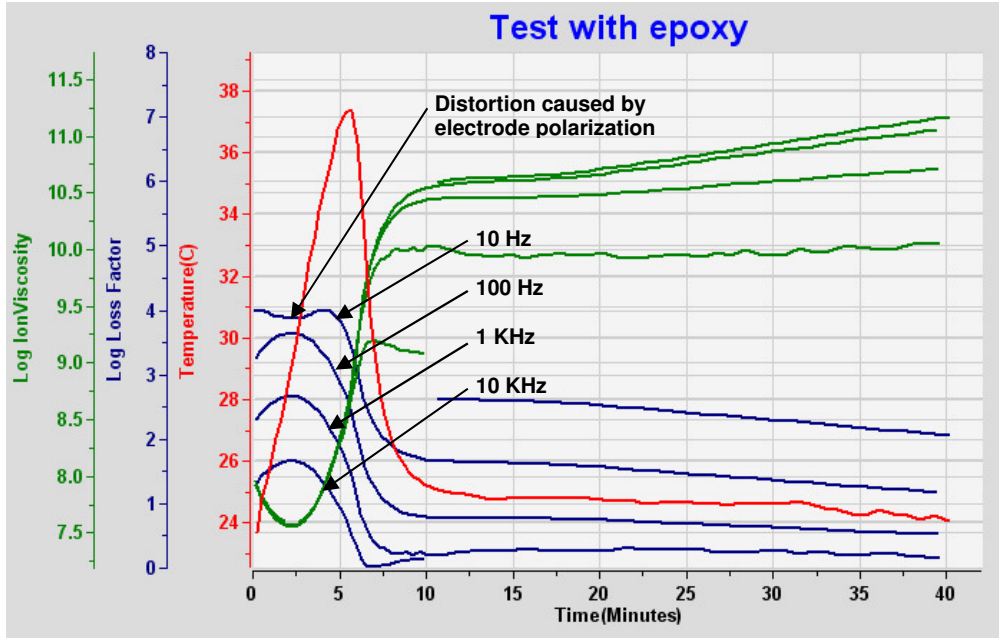

Figure 29-9
Correction of the boundary layer effect

$\text{Log}(e''x)$ is the logarithm of the original loss factor $e''x$, which was acquired during cure of an epoxy resin. $\text{Log}(e''x)$ data at 10 Hz shows distortions and the characteristic double hump from the boundary layer effect. This anomaly occurs at the time of maximum loss factor—maximum conductivity—as indicated by peaks from data at the higher frequencies of 100 Hz, 1.0 kHz and 10 kHz. $\text{Log}(e'')$ is the logarithm of the corrected loss factor e'' , and the corrected 10 Hz curve shows a loss factor peak consistent with peaks for higher frequencies.

Figure 29-10 compares data from the cure of this epoxy both before and after boundary layer correction.



Epoxy cure data showing distortion due to boundary layers

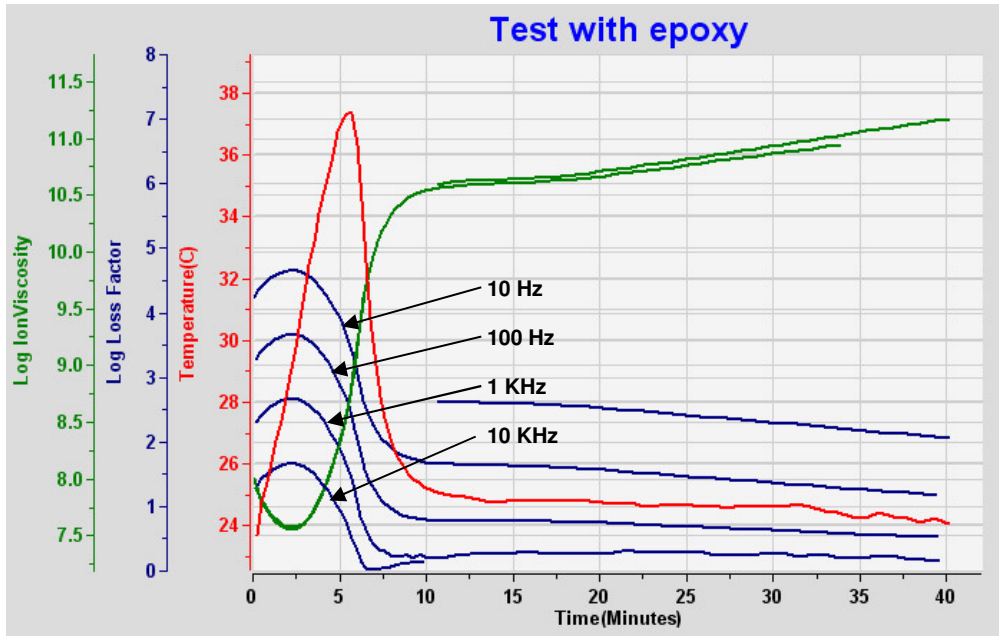

Epoxy cure data after electrode polarization correction

Figure 29-10
Comparison of data before and after electrode polarization correction

Note loss factor is inversely proportional to frequency, as given by equation 29-4, repeated below:

(eq. 29-4)
$$\epsilon'' = \sigma' / (\epsilon_0 \omega)$$

During the early portion of cure, frequency independent DC conductivity (σ_{DC}) typically dominates loss factor. For the epoxy of this example, the corrected curves for 10 Hz, 100 Hz, 1 kHz and 10 kHz are all parallel and separated by factors of 10, as expected.

References

1. Day, D.R.; Lewis, J.; Lee, H.L. and Senturia, S.D., "The Role of Boundary Layer Capacitance at Blocking Electrodes in the Interpretation of Dielectric Cure Data in Adhesives," *Journal of Adhesion*, V18, p.73 (1985)
2. MacDonald, J.R., *Phys. Rev.*, v92, p.4 (1953)



Lambient Technologies, LLC
649 Massachusetts Ave., Cambridge MA 02139, USA
(857) 242-3963
<https://lambient.com>
info@lambient.com